

NOTES:

1. SUBSTRATE: FUSED SILICA
2. COATING:
S1 & S2: R(ABS) <0.25% @ 355nm
DAMAGE THRESHOLD, PULSED:
7.5 J/cm2 @ 355nm, 20ns, 20Hz
3. CENTERING: < 1 ARCMIN
4. RoHS: COMPLIANT
5. ASPHERIC SURFACE DESCRIBED BY THE FOLLOWING EQUATION AND COEFFICIENTS SHOWN IN TABLE BELOW

$$Z_{ASPH}(Y) = \frac{(\frac{1}{RADIUS}) * Y^2}{1 + \sqrt{1 - (1+k) * (\frac{1}{RADIUS})^2 * Y^2}} + D * Y^2 + E * Y^4 + F * Y^6 + G * Y^8 + H * Y^{10} + J * Y^{12} + L * Y^{14}$$

**FOR INFORMATION ONLY:
DO NOT MANUFACTURE
PARTS TO THIS DRAWING**

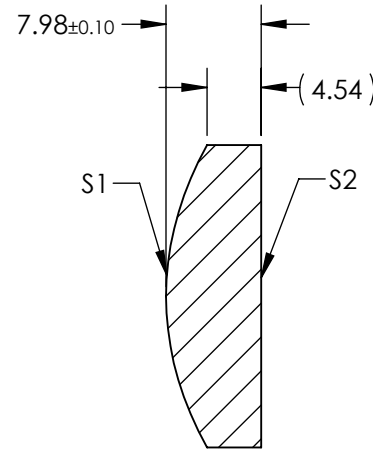
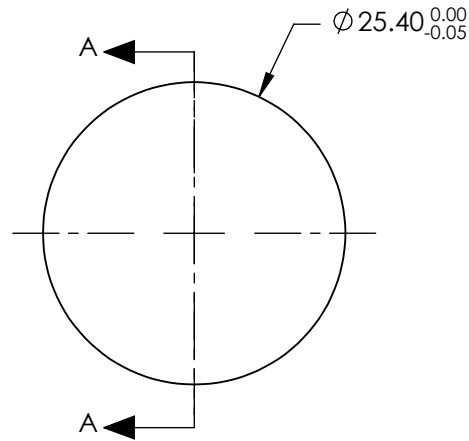

SECTION A-A

COEFFICIENT TABLE	
COEFFICIENT	S1
SEMI-DIAMETER	1.270000E+01
(1/RADIUS)	4.134623E-02
k	-6.748308E-01
D	0.000000E+00
E	9.396655E-07
F	3.220876E-10
G	8.065593E-14
H	0.000000E+00
J	0.000000E+00
L	0.000000E+00

SPECIFICATIONS SUBJECT TO CHANGE WITHOUT NOTICE
DIMENSIONS ARE FOR REFERENCE ONLY

	S1	S2
SHAPE	CONVEX	PLANO
SURFACE QUALITY	10-5	10-5
CLEAR APERTURE	Ø21.40	Ø21.40
BEVEL	PROTECTIVE AS NEEDED	PROTECTIVE AS NEEDED

EFL: 50.8mm			Edmund Optics®
BFL: 45.39mm			
THIRD ANGLE PROJECTION	TITLE	25.4mm Dia x 50.8mm FL, 355nm V-Coat, λ/40 Laser Grade Aspheric Lens	
ALL DIMS IN	mm	DWG NO	39556
			SHEET 1 OF 1