

**FOR INFORMATION ONLY:
DO NOT MANUFACTURE
PARTS TO THIS DRAWING**

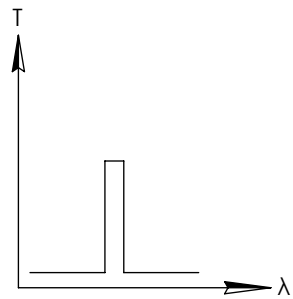

BANDPASS FILTER

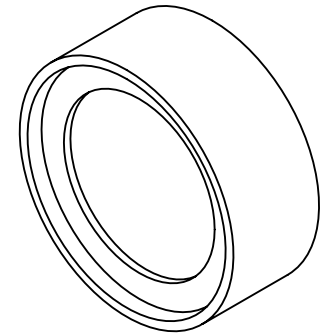
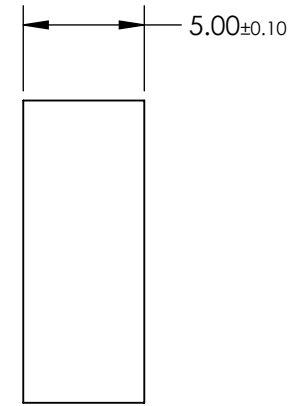
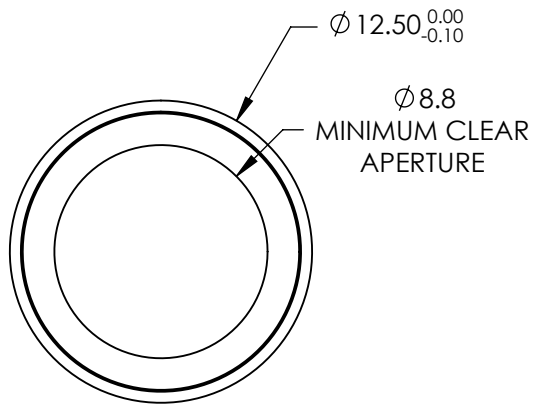

REV. A	VALUE
CENTER WAVELENGTH (CWL)	280 ± 2nm
FULL WIDTH HALF MAX (FWHM)	10 ± 2nm
MINIMUM TRANSMISSION	60%
BLOCKING	220 - 650nm
SURFACE QUALITY	80-50
CONSTRUCTION	MOUNTED IN BLACK ANODIZED ALUMINUM RING
COATING TYPE	HARD COATED
DURABILITY	MIL-C-48497A, SECTION 3.4.1
ENVIRONMENTAL	MIL-STD-810F, SECTION 507.4

SPECIFICATIONS SUBJECT TO CHANGE WITHOUT NOTICE
DIMENSIONS ARE FOR REFERENCE ONLY

EO® **Edmund Optics**®

THIRD ANGLE PROJECTION		TITLE	OD4, Ø12.5mm, 280nm X 10nm BP FILTER
ALL DIMS IN	mm	DWG NO	35874
			SHEET 1 OF 1